

### Description

Single, two and three pole magnetic and hydraulic-magnetic circuit breakers with trip-free mechanism and toggle actuation. A choice of fast magnetic only or hydraulically delayed switching characteristics (S-type MO or HM CBE to EN 60934) ensures suitability for a wide range of applications. Featuring a combi-foot design for symmetric rail mounting. Low temperature sensitivity at rated load. Approved to CBE standard EN 60934 (IEC 60934).

### Typical applications

Power supplies, control equipment, communication systems, EDP systems.

### Standard current ratings and typical internal resistance values

Current rating (A)	Internal resistance (Ω)		
	F1	K1, M1, T1	K2, M2, T2
0.02	1493	2669	2457
0.05	276	452	376
0.1	58	100	94
0.25	8.2	15.5	14.7
0.5	2.3	3.9	3.2
0.75	0.98	1.65	1.56
1	0.58	0.95	0.90
2	0.145	0.26	0.20
2.5	0.096	0.15	0.15
3	0.065	0.10	0.10
5	0.025	0.042	0.040
6	< 0.02	0.029	0.028
8	< 0.02	< 0.02	< 0.02
10	< 0.02	< 0.02	< 0.02
12	< 0.02	< 0.02	< 0.02
15	< 0.02	< 0.02	< 0.02
16	< 0.02	< 0.02	< 0.02
20	< 0.02	< 0.02	< 0.02
25	< 0.02	< 0.02	< 0.02
30	< 0.02	< 0.02	< 0.02
40	≤ 0.01	≤ 0.01	-
50	≤ 0.01	≤ 0.01	-

### Approvals

Authority	Voltage ratings	Current ratings
VDE (EN 60934)	3 AC 415 V; AC 240 V; DC 80 V	0.02...30 A 1 to 6-pole
	DC 80 V	0.02...50 A 1-pole
UL1077, CSA	DC 80 V	0.02...50 A 1 to 6-pole
	3 AC 250 V; AC 250 V	0.02...30 A 1 to 6-pole
CCC	3 AC 415 V; AC 240 V	0.02...30 A
	DC 80 V	0.02...50 A 1, 2-pole



### Technical data

**For further details please see chapter: Technical Information**

Voltage rating	3 AC 415V; AC 240V (50/60Hz); DC 80V (higher DC voltages to special order)	
Current rating range	0.02...50 A single pole (40 + 50 A DC only) 0.02...30 A multipole	
Auxiliary circuit	1 A, AC 240 V/DC 65 V; 0.5 A DC 80 V	
Typical life	3 AC 415 V AC 240 V: 0.02...30 A 6,000 operations at 1 x I <sub>N</sub> , inductive 10,000 operations at 1 x I <sub>N</sub> , resistive	
WDC 80 V:	0.02...25 A 6,000 operations at 1 x I <sub>N</sub> , inductive 0.02...30 A 10,000 operations at 1 x I <sub>N</sub> , resistive 40 + 50 A 6,000 operations at 1 x I <sub>N</sub> , resistive	
Ambient temperature	-40...+85 °C (-40...+185 °F)	
Insulation co-ordination (IEC 60664 and 60664A)	rated impulse withstand voltage 2.5 kV reinforced insulation in operating area	pollution degree 2
Dielectric strength (IEC 60664 and 60664A)	test voltage operating area pole to pole main to aux. circuit	AC 3,000 V AC 1,500 V AC 1,500 V
Insulation resistance	> 100 MΩ (DC 500 V)	
Interrupting capacity IEC 60934 - test sequence	6 x I <sub>N</sub> at AC; E 4 x I <sub>N</sub> at DC	
Interrupting capacity (UL 1077)	I <sub>N</sub>	0.02...20 A 25...30 A
	AC:	1-pole AC 250 V/3,500A AC 250 V/3,500A 2-pole AC 250 V/3,500A AC 250 V/5,000A 3-pole 3AC 250V/3,500A 3AC250V/5,000A
	DC:	1-pole 0.02...50 A DC 80 V/3,500 A 2-pole 0.02...30 A DC 80 V/3500 A
Degree of protection (IEC 60529/DIN 40050)	operating area IP40 terminal area IP20	
Vibration	with toggle down: 10 g at 0.9 I <sub>N</sub> directions 1, 2, 3, 4, 5: 10 g at 1 x I <sub>N</sub> with curves F1, F2: 10 g at 0.8 x I <sub>N</sub> in all planes. (57-2000 Hz) ± 0.76 mm (10-57 Hz) to IEC 60068-2-6, test Fc 10 frequency cycles/axis	
Shock	directions 1, 2, 3, 4, 5: 100 g (11 ms) at 1 x I <sub>N</sub> direction 6: 100 g (11 ms) at 0.8 x I <sub>N</sub> with curves F1, F2: 100 g (11 ms) at 0.8 x I <sub>N</sub> to IEC 60068-2-27, test Ea	
Corrosion	96 hours at 5 % salt mist, to IEC 60068-2-11, test Ka	
Humidity	240 hours at 95 % RH, to IEC 60068-2-78, test Cab	
Mass	approx. 98 g per pole	

**Ordering information**

<b>Type No.</b>	
8340	circuit breaker with toggle actuator
<b>Mounting</b>	
T	rail mounting
<b>Configuration</b>	
1	snap-on installation
<b>Number of poles</b>	
1	single pole protected
2	two pole protected
3	three pole protected
	} magnetic, hydraulic-magnetic
<b>Panel hardware</b>	
0	without panel hardware
<b>Terminal design (main contact)</b>	
K1	recessed screw/pressure plates M4
<b>Characteristic curve</b>	
<b>Curve F, instantaneous trip:</b>	
F1	DC trip at $1.01-1.5 \times I_N$
<b>Curve K, short delay:</b>	
K1	DC trip at $2 \times I_N$ 0.16-1.2 s
K2	AC 60/50 Hz trip at $2 \times I_N$ 0.13-1.6 s
<b>Curve M, medium delay:</b>	
M1	DC trip at $2 \times I_N$ 0.6-7.5 s
M2	AC 60/50 Hz trip at $2 \times I_N$ 2.2-20 s
<b>Curve T, long delay:</b>	
T1	DC trip at $2 \times I_N$ 10-70 s
T2	AC 60/50 Hz trip at $2 \times I_N$ 15-150 s
<b>Other characteristic curves to special order</b> (e.g. pulse-delayed, high inrush currents, capacitive loads)	
<b>Actuator colour / design</b>	
A	black, long toggle
K	black, short toggle
<b>Marking on actuator</b>	
0	without marking
L	I-O; ON-OFF
M	I-O; ON-OFF ( $I_N$ , $U_N$ , trip curve, schematic diagram on housing top)
N	I-O; ON-OFF ( $I_N$ , on housing top)
<b>Auxiliary contacts</b>	
H0	without auxiliary contacts
H1	with auxiliary contact
H2	with auxiliary contact on one pole only (multipole)
<b>Auxiliary contact function</b> (see internal connection diagrams)	
2	1 N/O contact
3	1 N/C contact
<b>Auxiliary contact terminal design</b>	
6	screw/pressure plate M3
<b>Current ratings</b>	
0.02...50 A	
8340 - T 1 1 0 - K1 M1 - A L H1 2 6 - 10 A ordering example	

4

This is a metric design and millimeter dimensions take precedence ( $\frac{mm}{inch}$ )

**Dimensions**

**long toggle**

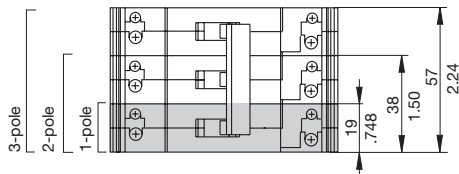
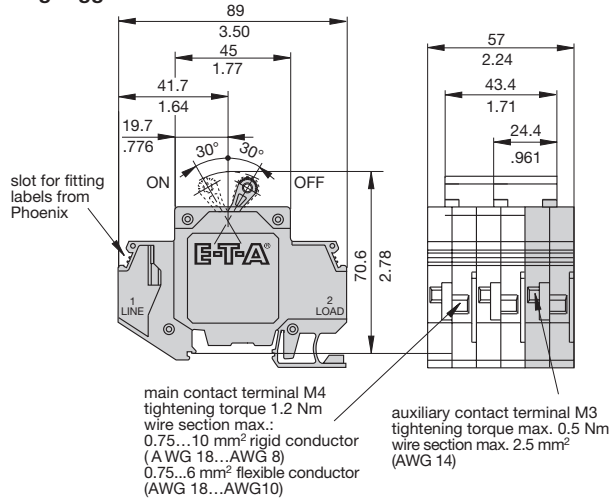

**short toggle**

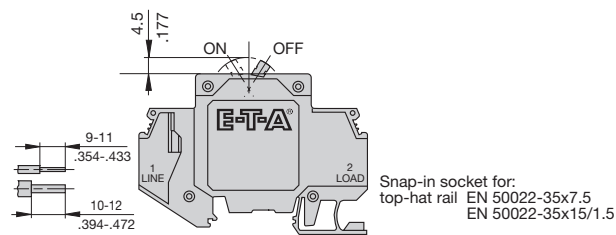

**Installation drawing**

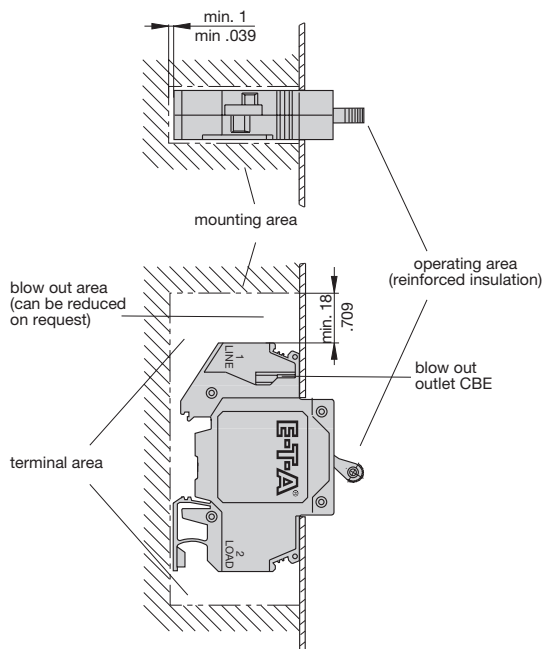

**Internal connection diagrams**

**1-pole protected magnetically**

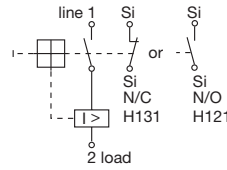

**multipole**

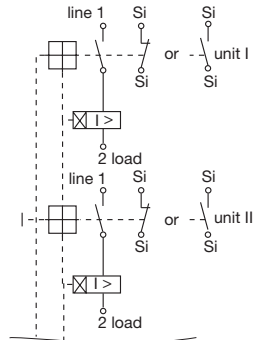

**1-pole protected hydraulic-magnetically**

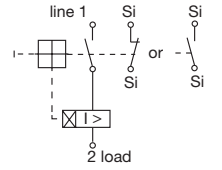

unit III  
:  
unit IV  
:  
:

Optional N/C or N/O auxiliary contact (Si)

**Shock directions**

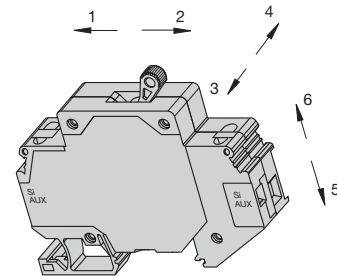

Typical time/current characteristics at 23 °C / +73.4 °F

**Curve F1 (instantaneous) for DC**

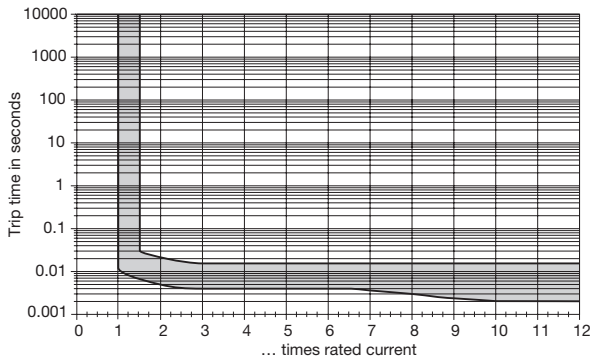

**Curve M1 (medium delay) for DC**

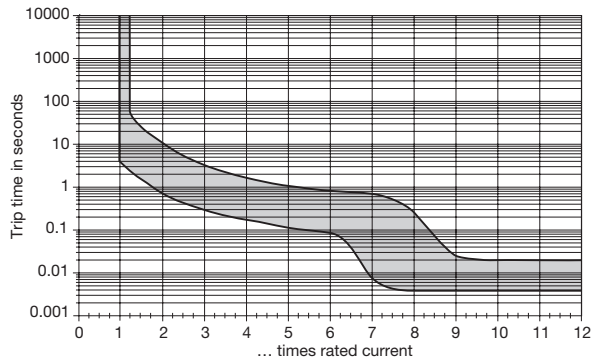

**Curve K1 (short delay) for DC**

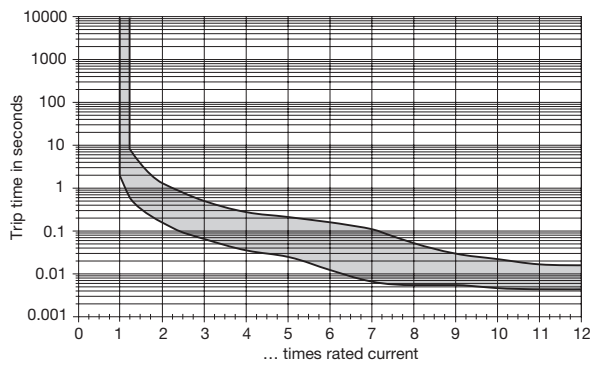

**Curve M2 (medium delay) for AC 50/60 Hz**

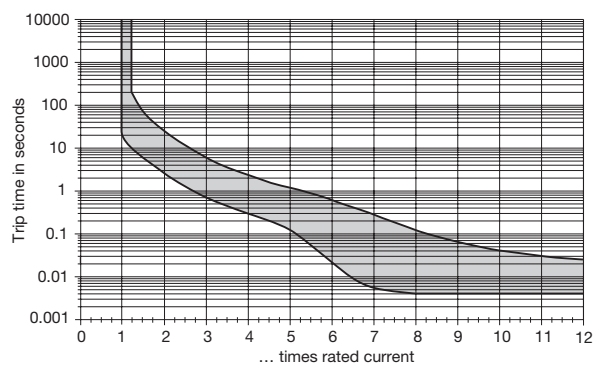

**Curve K2 (short delay) for AC 50/60 Hz**

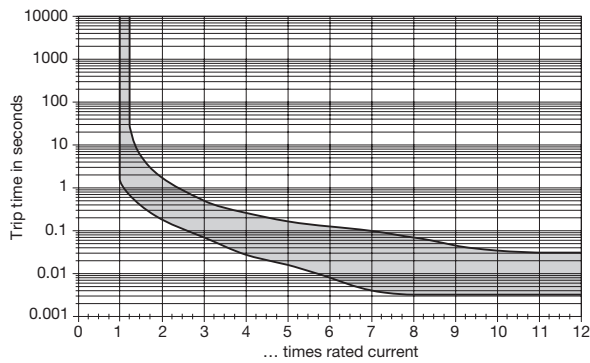

**Curve T1 (long delay) for DC**

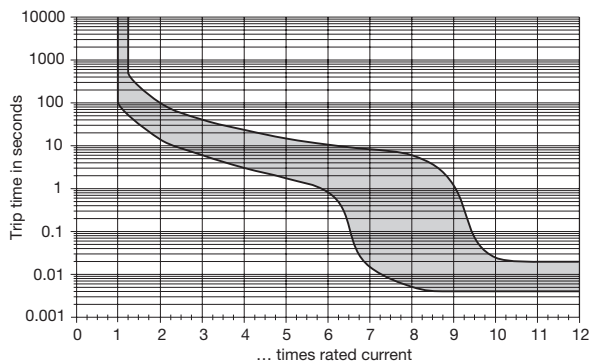

**Curve T2 (long delay) for AC 50/60 Hz**

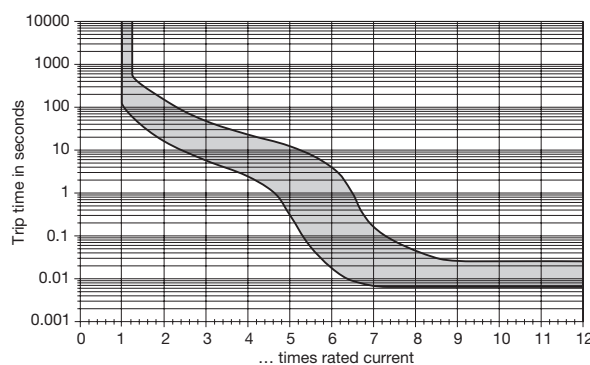

**N.B.** All curves will only be maintained if the escutcheon is mounted on a vertical surface. **Other characteristic curves to special order (e. g. with impulse delay for inrush peaks).**

4

**Accessories**

**Connector bus links -K10**

**X210 589 01**/2.5 mm<sup>2</sup>, (AWG 14) (black) up to 20 A max. load  
**X210 589 02**/1.5 mm<sup>2</sup>, (AWG 16) (brown) up to 13 A max. load

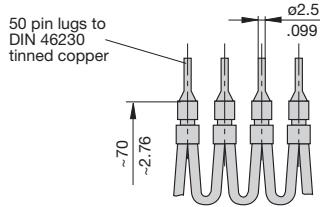

**Busbar 1-pole**  
**Y 308 495 01**

The one metre long busbars can be cut to suitable lengths. Plug-on caps can be fitted on the ends to provide brush contact protection.

I<sub>max</sub> - busbar 100 A (40 °C)

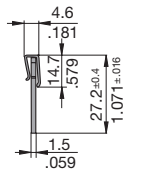
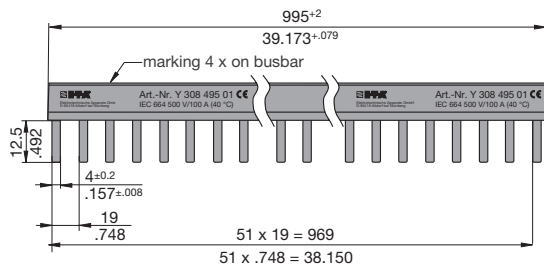

**Plug-on cap, 1-pole**  
**Y 307 851 01**



**Busbar 2-pole**  
**Y 308 496 01**

I<sub>max</sub> - busbar 100 A (40 °C)

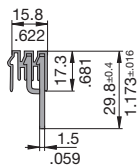
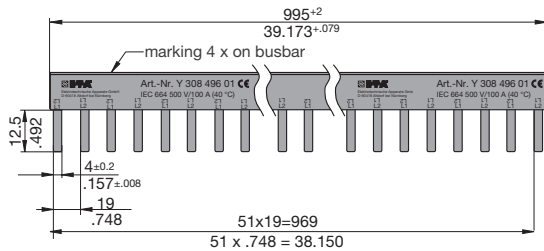

**Plug-on cap, busbar 2/3-pole**  
**Y 308 506 01**

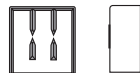

**Busbar 3-pole**  
**Y 308 497 01**

I<sub>max</sub> - busbar 100 A (40 °C)

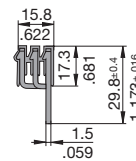
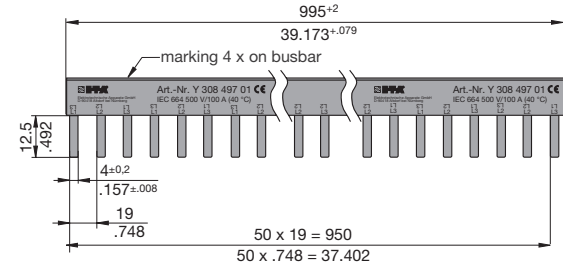

**Plug-on cap, busbar 2/3-pole**  
**Y 308 506 01**

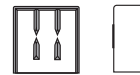

**Supply terminal I<sub>max</sub> 63 A**  
**Y 308 504 01**

Max. tightening torque of terminal screw 2 Nm  
 Max. cable cross section: 25 mm<sup>2</sup> / single strand  
 16 mm<sup>2</sup> / multistrand with wire end ferrule

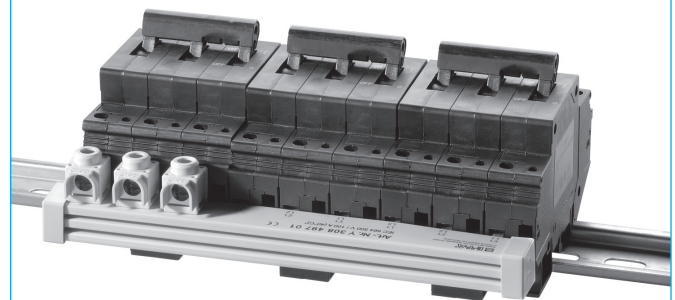
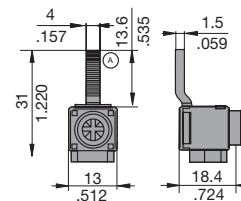

**Caution:**

When using multipole busbars please leave at least one pole's width between two adjacent line entry terminals.

This is a metric design and millimeter dimensions take precedence (mm / inch)

All dimensions without tolerances are for reference only. In the interest of improved design, performance and cost effectiveness the right to make changes in these specifications without notice is reserved. Product markings may not be exactly as the ordering codes. Errors and omissions excepted.