

Description

Single or two pole isolation switches to IEC 60947/EN 60947 with toggle actuation. Options include auxiliary contacts and remote operation - disconnection only, or disconnection and re-connection.

Typical applications

Vehicles of all types (including tankers), boats, battery powered systems.

Ordering information

Type No.

921 single pole switch

922 double pole switch

Terminal design

K12 for single pole version

K60 for single pole version

K61 for double pole version

K72 for double pole version

Mounting

5 mounting brackets - surface mounting

Auxiliary contacts (blade terminals 6.3x0.8)

Si2 one N/O

2Si2 two N/O

Si10 one each N/O and N/C

Remote operation

FA remote disconnection

FC electrical remote disconnection (FA) and re-connection (FE)

BC-FA electrical remote disconnection and manual remote re-connection

Coil voltage

12 AC/DC 12 V

24 AC/DC 24 V

Current ratings

240 A type 921

120 A type 922

921 -K60 - 5 - Si2 - FA 24 - 240 A ordering example

The exact part number required can be built up from the table of choices shown above. Ordering references for optional features should be omitted if not required.



921
single pole

922
double pole

Technical data

Voltage rating	DC 12 V; DC 24 V	
Current rating range	240 A type 921, single pole 120 A type 922, double pole	
Auxiliary contact rating	6 A at DC 24 V 1 A at DC 110 V	
Electrical remote disconnection (-FA):	operating voltage DC 12 V or DC 24 V operating current approx. 18 A or approx. 12 A max. pulse time 10 ms < t _{ON} < 20 ms / t _{OFF} > 10 s switching time < 20 ms	
Electrical remote re-connection (-FE):	operating voltage DC 12 V or DC 24 V operating current approx. 30 A or approx. 15 A max. pulse time 0.1 s < t _{ON} < 1.2 s / t _{OFF} > 60 s switching time < 100 ms	
Typical life	10,000 operations at I _N 20,000 operations mechanical	
Ambient temperature	-40...+75 °C (-40...+167 °F)	
Insulation co-ordination (IEC 60664 and 60664A)	rated impulse withstand voltage 6 kV	pollution degree 3
Dielectric strength (IEC 60664 and 60664A)	test voltage operating area AC 3,300 V pole/pole AC 3,300 V main to aux. circuit AC 2,200 V aux. circuits 11-12 to 13-14 AC 1,000 V	
Insulation resistance	> 100 MΩ (DC 500 V)	
Switching capacity	Type 921 2,500A for 1s at +23°C 600A for 1min at +23°C 600A for 2min at -23°C 600A for 90s at 0°C	Type 922 1,500A for 1s at +23°C 600A for 30s at +23°C 600A for 1min at -23°C 600A for 45s at 0°C
Degree of protection (IEC 529/DIN 40050)	operating area IP40 terminal area IP00	
Vibration	5 g (57-200 Hz), ± 0.38 mm (10-57 Hz) to IEC 60068-2-6, test Fc 10 frequency cycles/axis	
Shock	25 g (11 ms), to IEC 60068-2-27, test Ea	
Corrosion	96 hours at 5 % salt mist to IEC 60068-2-11, test Ka	
Humidity	240 hours at 95 % RH, to IEC 60068-2-3, test Ca	
Mass	approx. 900 g base unit + approx. 400 g remote disconnection + approx. 100 g remote re-connection	

This is a metric design and millimeter dimensions take precedence $\left(\frac{\text{mm}}{\text{inch}}\right)$

All dimensions without tolerances are for reference only. In the interest of improved design, performance and cost effectiveness the right to make changes in these specifications without notice is reserved. Product markings may not be exactly as the ordering codes. Errors and omissions excepted.

Dimensions

921-K12-5-...-BC-FA..

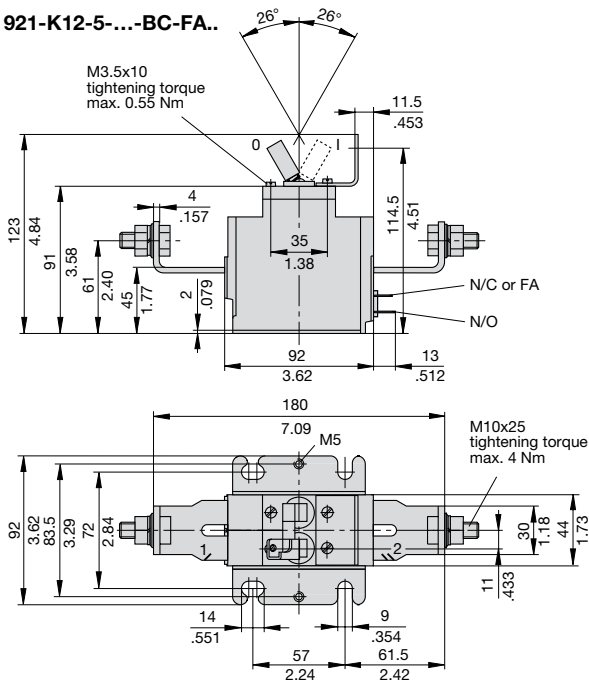

921-K60-...-FA

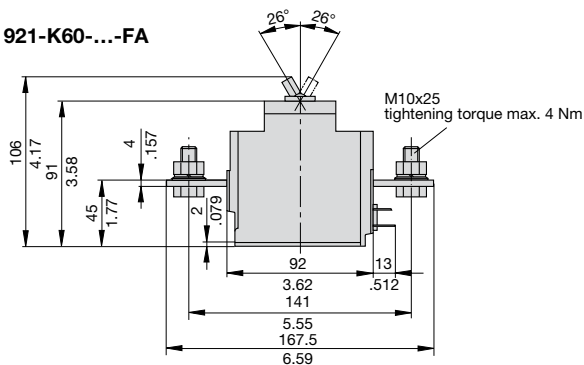

922-K72-5-...-FC

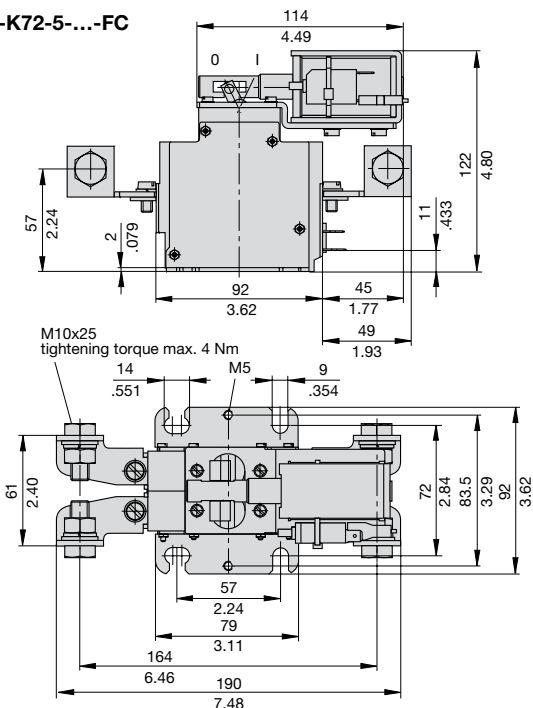

Dimensions types 922

922-K61-5-...-FC

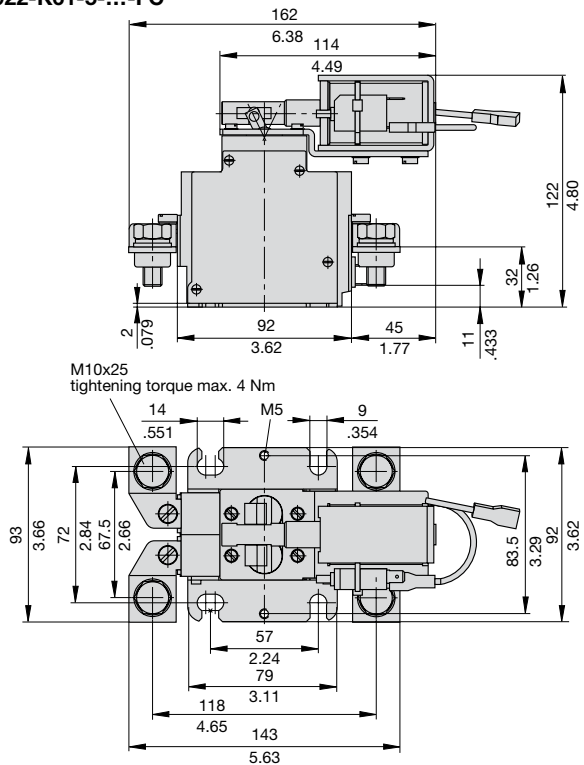

Shock directions

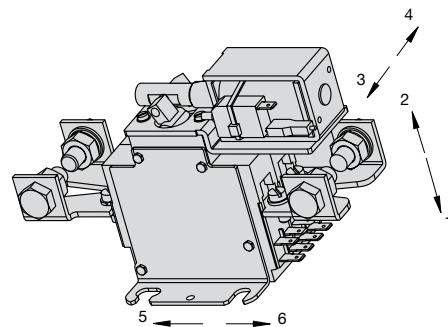

Internal connection diagrams

921

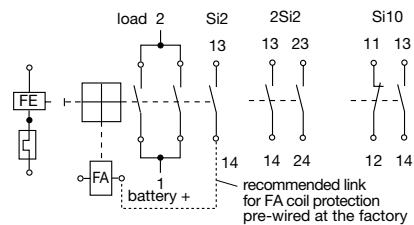

922

